

Highly Flexible

Easy to Use

Quiet, Fast, Efficient Marking

MarkMaster™ Graphical Windows Software

USB Interface

Industrial and Commercial Applications

PRYOR
MARKING TECHNOLOGY

Marktronic™ USB Markmate



USB Plug and Play Dot Marking Machine

A bench mounted, fully programmable dot marking machine in a low cost simple to use package. PC Driven via the simple to use, industry leading MarkMaster™ Windows software.

Applications Include:

- Programmable marking•Component Identification•Component traceability•Serial numbering
- Logo marking•Security marking•Health & safety appliance marking•Certification marking
- Decorative trophy and award marking•Time and date marking•Part numbering
- Batch and shift coding•Calibration systems•Label and tag marking

intelligent marking solutions



technical specifications

Marking Area:	100mm x 75mm
Std. Character Sizes:	0.18mm - 99.9mm in increments of 0.18mm
Marking Formed:	5 x 7, 7 x 9, Varidot, all Windows True Type fonts*, DXF, HPGL
Marking Speed:	Variable, depends on application
Min PC Req:	1GHz Pentium or equivalent with USB port
Operating System:	Windows 2000, Windows XP, Windows Vista
Weight:	13kg

EMC Approved to EN 50081-2 & IEC 801-2

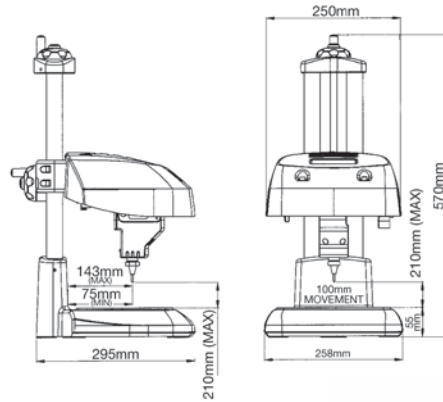

Pryor reserve the right to amend product specifications without notice.

Highly Flexible



Ideal for a wide range of industrial and commercial applications. The USB connectivity brings printer like functionality to the field of permanent component dot marking. 100mm by 75mm marking area allowing multi-component marking, saving time. Variable force control to ensure optimum mark depth for all engineering materials up to 62 Rc (800 Hv). The lead-screw driven marking head guarantees dot precision unmatched on other low cost systems.



Easy to use out of the box

The compact ergonomic design has been created with ease of use in mind. High functionality, simple to use, MarkMaster™ software ensures operator training is minimised and production efficiency is maximised. The multilingual user interface allows users to choose between different character fonts and type sizes as well as angular and arc marking, serial numbers, date and time marking.

Quiet, Fast, Efficient Marking

Requiring no air supply and powered only by a standard 220/110 volt electric source the MarkMate is both highly efficient, and significantly quieter than pneumatically actuated systems.

Wide Range of Options

Standard hardware options include magnetic table, machine 'T' slot table and label fixture. Custom designed fixtures are also available on request. Extended Warranty packages available.

MarkMaster™ Software



Easy to use Windows based package. Enables on-screen creation of marking layouts using a simple drag and drop graphical interface. Allows the creation and marking of logos using the in-built graphics tools alternatively DXF and HPGL formats can be imported from other CAD systems. The advanced trial run feature allows layouts to be rapidly created and checked before the part is marked. The marked text is positioned on-screen while the machine outlines the marking position on the part itself.

MarkMaster™ Features include

- Range of high speed fonts (5x7, 7x9, Varidot)
- Advanced Trial Run
- Time and Date marking
- Variable and Serial Number marking
- Angled, Arc & Reverse marking
- Graphics tools
- CAD File import facility

MarkMaster™ Advanced features include

- (Upgrade available as optional extra)*
- Supports all Windows True Type Fonts for decorative marking
- Database connectivity for marking data queries
- Database connectivity for duplicate data checking
- Security Password features
- Data logging for marking report generation

** Only available with MarkMaster™ Advanced Software upgrade*



MARKING PRODUCTS, INC.

When identification is critical for traceability or product impact, a quality mark is required. Monode combines creative engineering with a full range of marking solutions to meet your needs. Over a half-century of progress as a trusted "parts marking problem solver" ... that's Monode!

Contact Us:

Telephone: 440-975-8802

Fax: 440-975-1364

The Web: www.monode.com

Email: sales@monode.com

Corporate Office: 9200 Tyler Boulevard • Mentor, Ohio 44060



**Quality Marking
Equipment with
Integrated Machine
Vision Solutions**