

- STEEL TYPE
- ROLL DIES
- HAND STAMPS
- HOT STAMPS
- DIE INSERTS
- CUSTOM ENGRAVING
- E.D.M. SERVICES
- MARKING MACHINERY

MONODE™ STEEL STAMP, INC.

149 High Street • New London, Ohio 44851
 Phone: 419-929-3501 • Fax: 419-929-8806



Serializing Heads

- Consecutive • Random
- Duplicate • Letters or Symbols

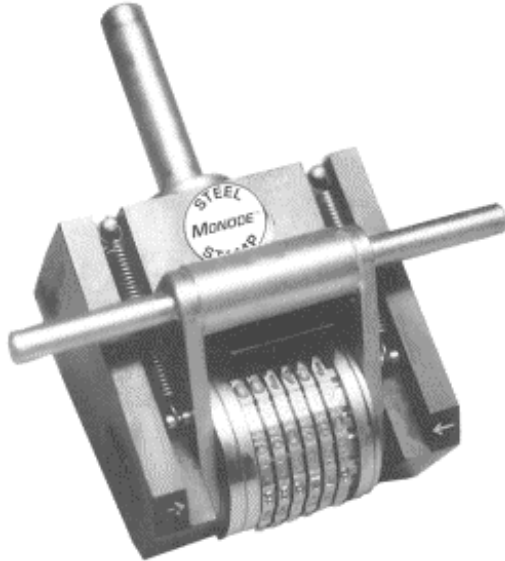

Special Heads

Special Serializing Heads can be manufactured to meet any unusual marking requirement. Among the specials would include:

- Hot Stamping - Hot Foil Marking
- Selective - Finger Pawl
- Barrel Style - Roll Marking

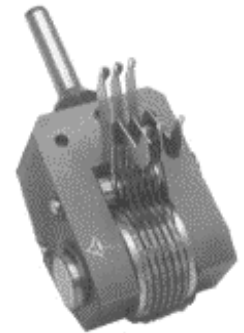

Consecutive Serial numbers can be indexed by hand, trip lever, or pneumatic / mechanical actuator.

OVERALL DIMENSIONS OF THE TWO STANDARD FRAME SIZES

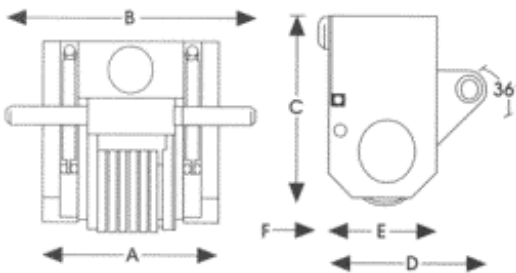

mm	A	B	C	D	E	F
STANDARD SMALL FRAME	62	100	63	52	38	4
STANDARD LARGE FRAME	106	152	96	88	60	6

OVERALL LENGTHS OF IMPRESSION

The chart below shows the actual inscription lengths for the number of wheels and character size required using standard style and spacing.

Using condensed style characters the size above can be used without changing the overall length of inscription from that shown for the smaller size. Broad style characters the size below can be used without changing the overall length of inscription from that shown for the larger size.

Up to six wheels in a head can have automatic action.

SIZE	NUMBER OF WHEELS											
mm	2	3	4	5	6	7	8	9	10	11	12	
1.5	3.5	5.8	8.1	10.5	12.8	15.7	17.5	19.8	22.2	24.5	26.8	STANDARD SMALL FRAME
2.0	4.3	7.1	9.9	12.7	15.5	18.3	21.1	23.9	26.7			
2.5	5.0	8.1	11.2	14.3	17.4	20.6	23.7	26.8				
3.0	5.8	9.3	12.8	16.3	19.8	23.3	26.8					
4.0	7.3	11.6	15.9	20.2	24.5	28.8	33.1	37.4	41.7	46.0	STANDARD LARGE FRAME	
5.0	8.8	13.8	18.8	23.8	18.8	33.8	38.8	43.8				
6.0	10.6	16.6	22.6	28.6	34.6	40.6	40.6					

- STEEL TYPE
- ROLL DIES
- HAND STAMPS
- HOT STAMPS
- DIE INSERTS
- CUSTOM ENGRAVING
- E.D.M. SERVICES
- MARKING MACHINERY

MONODE™ STEEL STAMP, INC.

149 High Street • New London, Ohio 44851
 Phone: 419-929-3501 • Fax: 419-929-8806



Hand Numbers

CHARACTERS

Standard wheels are cut with a sharp face, 0-9 (inclusive) with one blank station. Logos, symbols or letters can be engraved sharp face, flat face, or low stress. Condensed, concave, or wheels engraved with convex characters can be special ordered.

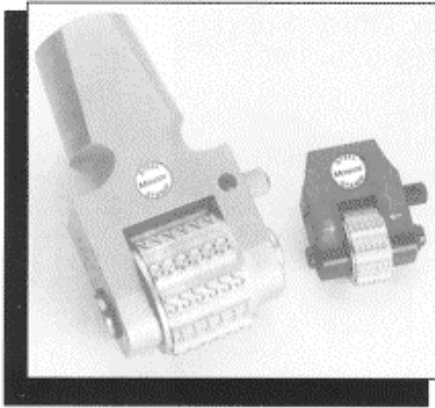

FEATURE:

The security pin not only fastens the wheels in position, but also transmits the impact energy in the body of the tool, directly to the point of marking.

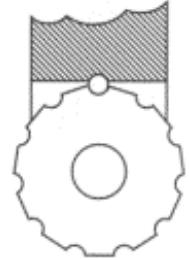

CHARACTER SIZE		NO. OF WHEELS (STANDARD UNIT)	LENGTH OF MARKED IMPRESSION		HAND OR HAND/MACHINE USE	MAXIMUM NO. OF WHEELS
MM	INCH		MM	INCH		
1.5	1/16	6	8.4	0.34	H/M	14
2.0	5/64	6	11.2	0.45	H/M	10
2.5	3/32	6	14.0	0.56	H/M	8
3.0	1/8	6	16.8	0.67	H/M	7
4.0	5/32	6	22.4	0.90	H	10
5.0	3/16	6	28.0	1.12	H	8
6.0	1/4	6	33.6	1.34	H	7

When suited with the appropriate shank the numberer can be used in a machine or by hand/hammer. Ideal for random numbering, with fast and simple character setting. The chart above shows the variety of configurations of the two standard frame sizes.

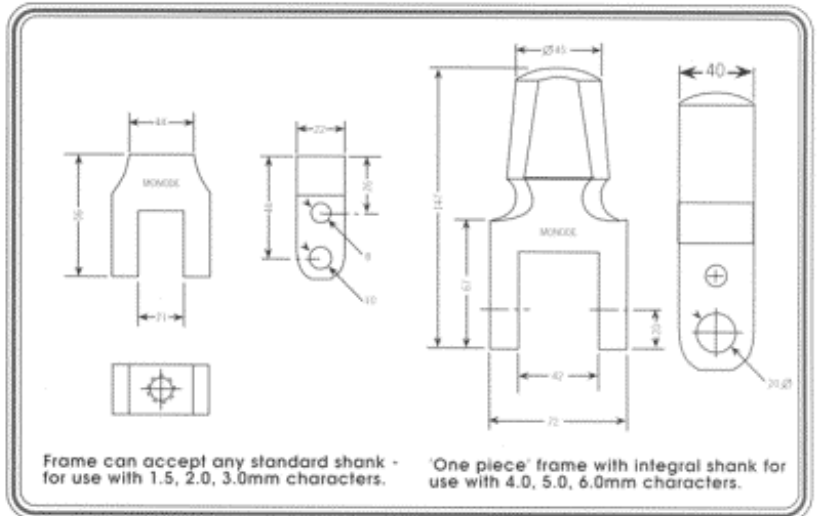
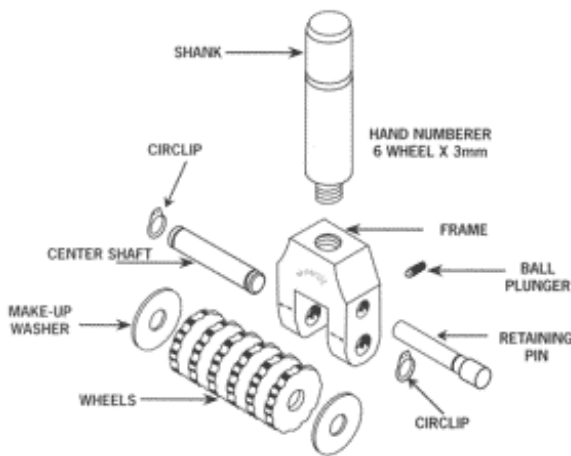

Manufacturers of Engraved Steel Stamps & Marking Equipment

SERVICE . . . INNOVATION . . . QUALITY . . . REFLECTED BY A GOOD IMPRESSION

