

Manufacturers and Distributors of Quality Marking Equipment



7620 Tyler Boulevard  
Mentor, OH 44060. USA  
Phone: (440) 975-8802  
Fax: (440) 975-1364  
Web: www.monode.com  
Email: sales@monode.com

# Monode™ Pad Printer Model MO-100



SINGLE COLOR BENCH MODEL  
3 X 6 IMAGE AREA  
MO-100-1



TWO-COLOR BENCH MODEL WITH  
SLIDING SHUTTLE, 3 X 3 IMAGE AREA  
MO-100-2



TWO-COLOR FLOOR MODEL WITH  
CONVEYOR, 3 X 3 IMAGE AREA  
MO-100-2

A WHOLE NEW WAY OF MARKING      A WHOLE NEW WAY OF MARKING      A WHOLE NEW WAY OF MARKING

**MONODE™**  
STEEL STAMP, INC.  
419-929-3501

  
**Imperial**  
STAMP & ENGRAVING

**Waldorf**  
Marking Devices™  
Division of Monode  
419-929-1541

## MONODE PAD PRINTING EQUIPMENT

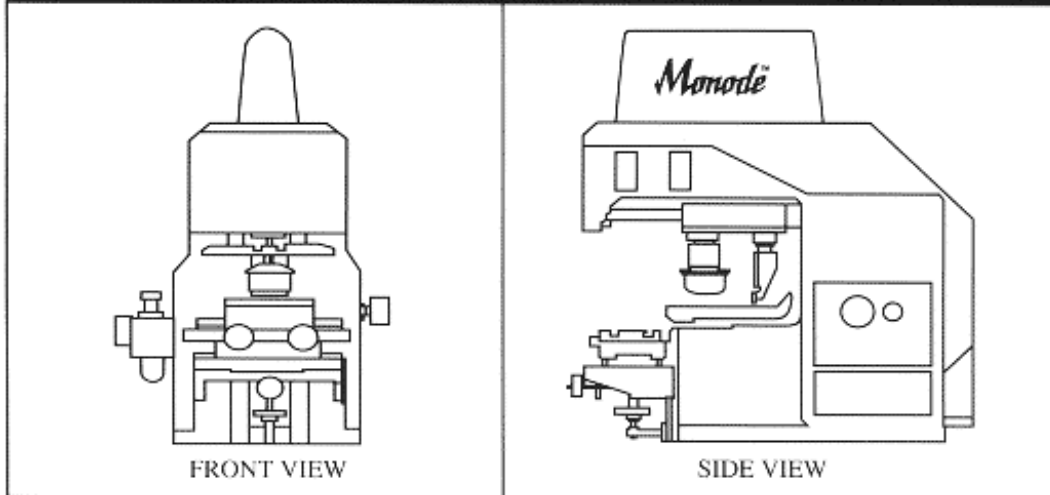

### ENGINEERING SPECIFICATIONS: Model MO-100

#### 100 SERIES PAD PRINTING MACHINE

POWER:	100 V AC, 60Hz
AIR:	3.0 CF/M, 60 PSI
MAX. PRINTING AREA:	Single Color 3 x 6 3 x 3 Standard Two Color 3 x 3
SIZE:	35 x 16 x 30 (Does not include base)
NET WEIGHT:	145 Lbs.
SHIPPING SIZE AND WEIGHT:	38 x 30 x 36 185 Lbs, GW
CYCLES PER HOUR:	1800 Max., actual production speeds vary upon operation speed and part parameters
<b>SPECIAL FEATURES:</b>	Logic control for precise set ups and maximum production speeds.  Tooling X-Y micro adjustments insures perfect alignment  E-Z Etch Cliche System from MONODE facilitates in plant addition of date codes or variable information on steel cliches.  Interface with two station shuttle, oval conveyor or index table is optional.  Steel welded floor stand is available.