

- STEEL TYPE
- ROLL DIES
- HAND STAMPS
- HOT STAMPS
- DIE INSERTS
- CUSTOM ENGRAVING
- E.D.M. SERVICES
- MARKING MACHINERY

## MONODE™ STEEL STAMP, INC.

149 High Street • New London, Ohio 44851  
 Phone: 419-929-3501 • Fax: 419-929-8806

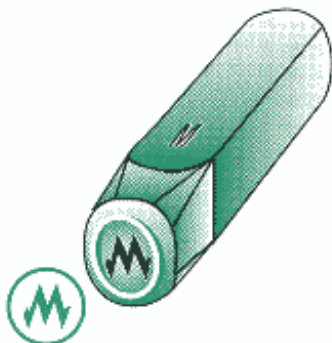

## MONODE™ STEEL STAMP, INC.

149 HIGH STREET  
 NEW LONDON, OHIO 44851  
 PHONE 419-929-3501  
 FAX 419-929-8806

- HEAVY DUTY HAND STAMPS
- LOGO, SYMBOL STAMPS & TYPE
- CUSTOM ENGRAVED MARKING DIES
- LOW STRESS, HEAVY DUTY INDUSTRIAL STAMPS
- MARKING MACHINES, TOOLING & FIXTURES
- REVERSE, POSI-DENT OR LOW STRESS STAMPS
- SERIALIZING HEADS, TYPE HOLDERS, ROLL STAMPS

AND FEATURING THE BEST OF . . .



*Imperial*

STAMP & ENGRAVING

SERVICE . . . INNOVATION . . . QUALITY . . . REFLECTED BY A GOOD IMPRESSION

- STEEL TYPE
- ROLL DIES
- HAND STAMPS
- HOT STAMPS
- DIE INSERTS
- CUSTOM ENGRAVING
- E.D.M. SERVICES
- MARKING MACHINERY

# MONODE™ STEEL STAMP, INC.

149 High Street • New London, Ohio 44851  
 Phone: 419-929-3501 • Fax: 419-929-8806

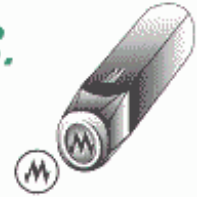

## HAND STAMPS

### MONODE SAF-T GRIP HEAVY DUTY HAND STAMPS

Char. Size	Steel Size, Inches		27 Pc. Letter Set Part No.	9 Pc. Figure Set Part No.
	Square	Length		
1/32"	1/4"	2-5/8"	10031/A-Z	10031/0-8
3/64"	1/4"	2-5/8"	10046/A-Z	10046/0-8
1/16"	5/16"	2-5/8"	10062/A-Z	10062/0-8
3/32"	5/16"	2-5/8"	10093/A-Z	10093/0-8
1/8"	5/16"	2-5/8"	10125/A-Z	10125/0-8
5/32"	3/8"	2-3/4"	10156/A-Z	10156/0-8
3/16"	3/8"	2-3/4"	10187/A-Z	10187/0-4
1/4"	7/16"	2-7/8"	10250/A-Z	10250/0-8
5/16"	1/2"	2-7/8"	10312/A-Z	10312/0-8
3/8"	5/8"	3-15/16"	10375/A-Z	10375/0-8
1/2"	5/8"	3-15/16"	10500/A-Z	10500/0-8



- Heavy Duty Shank
- Longer Shank

### MONODE ECONOMY HAND STAMPS

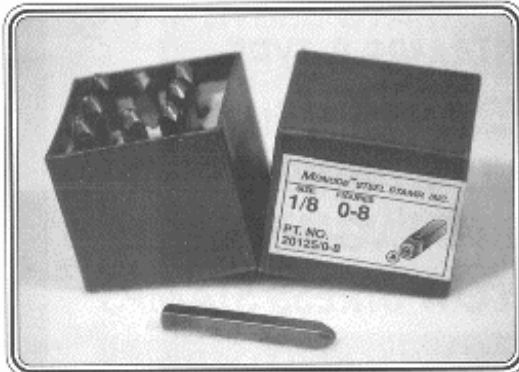

Char. Size	Steel Size, Inches		27 Pc. Letter Set Part No.	9 Pc. Figure Set Part No.
	Square	Length		
1/16"	1/4"	2-3/8"	20062/A-Z	20062/0-8
3/32"	1/4"	2-3/8"	20093/A-Z	20093/0-8
1/8"	1/4"	2-3/8"	20125/A-Z	20125/0-8
3/16"	5/16"	2-7/16"	20187/A-Z	20187/0-8
1/4"	3/8"	2-9/16"	20250/A-Z	20250/0-8
3/8"	1/2"	2-7/8"	20375/A-Z	20375/0-8
1/2"	5/8"	2-7/8"	20500/A-Z	20500/0-8

Lighter application stamps that feature:

- Smaller Shank
- Machine Formed Characters
- Low Cost

### PRESSURE DATA FOR MARKING

Character Size	Estimated Pressure To Stamp One Character*	Depth Of Impression*
1/16" - .062	.25 ton	.003
3/32" - .093	.50 ton	.0045
1/8" - .125	.75 ton	.006
5/32" - .156	1.00 ton	.007
3/16" - .187	1.88 ton	.008
1/4" - .250	2.10 ton	.010
5/16" - .312	3.00 ton	.013
3/8" - .375	4.00 ton	.016
7/16" - .437	4.75 ton	.016
1/2" - .500	5.70 ton	.017
5/8" - .625	7.50 ton	.020
3/4" - .750	9.25 ton	.020
7/8" - .875	11.00 ton	.020
1" - 1.00	13.00 ton	.020

The tonnage requirements for marking mild steel: Multiply the proper tonnage (see character size chart) X The number of characters to be stamped.

\* To determine pressures for aluminum or brass multiply the above tonnage by the .7. For high carbon steel, multiply by 1.5

\*\* To determine other impression depths, multiply the tonnage by the following:

- 1/2 of depth . . . . . 0.7
- 2 times depth . . . . . 1.3
- 3 times depth . . . . . 1.7

- STEEL TYPE
- ROLL DIES
- HAND STAMPS
- HOT STAMPS
- DIE INSERTS
- CUSTOM ENGRAVING
- E.D.M. SERVICES
- MARKING MACHINERY

# MONODE™ STEEL STAMP, INC.

149 High Street • New London, Ohio 44851  
 Phone: 419-929-3501 • Fax: 419-929-8806

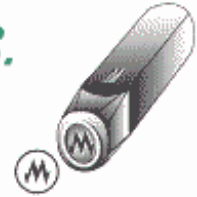

## TYPE

- Sharp face gothic characters.
- Heavy duty and industrial use.
- Standard sizes stocked.\*

### MAC-TYPE

High quality interchangeable straight and straight groove type manufactured for use in hand and press holders.

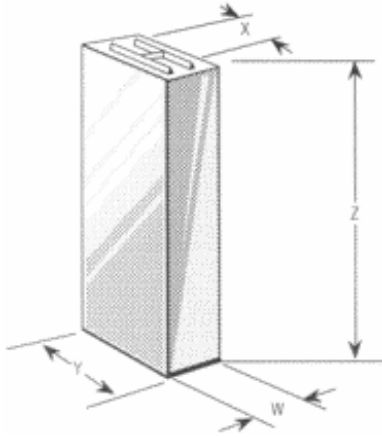

Char Size	Type Dimensions
3/64"	1/16 x 1/4 x 7/8*
1/16"	1/16 x 1/4 x 7/8*
3/32"	3/32 x 1/4 x 7/8*
1/8"	1/8 x 1/4 x 7/8*
5/32"	5/32 x 1/4 x 7/8*
3/16"	3/16 x 5/16 x 7/8*
1/4"	1/4 x 3/8 x 7/8*

\* Length may vary

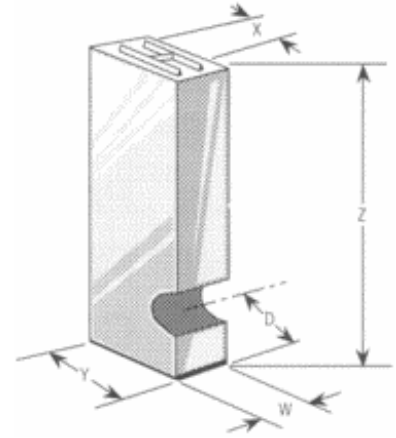

### HAND / PRESS TYPE HOLDERS

Monode's industrial type holders can be ordered for press operations or hand marking. Heavy duty shanks are press fit and pinned to ensure positive pressure transfer as well as non-rotating alignment.

Specify shank size diameter and length for press holders.

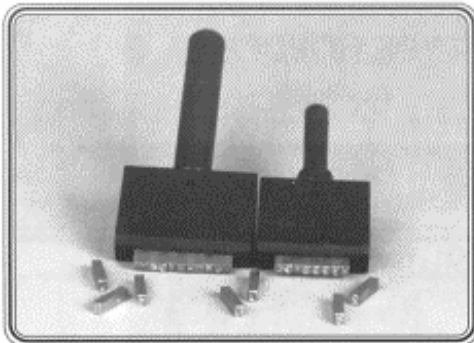

Model	Size of Opening	Capacity by Type Size		
		1/16	3/32	1/8
143410	1/4" x 3/4" x 1"	12	8	6
141010	1/4" x 1" x 1"	16	10	8
141810	1/4" x 1-1/8" x 1"	18	12	9
141410	1/4" x 1-1/4" x 1"	20	13	10
141210	1/4" x 1-1/2" x 1"	24	16	12
141310	1/4" x 1-3/4" x 1"	28	18	14
142010	1/4" x 2" x 1"	32	21	16

The alloy steel type holder ensures accurate type and logo-type alignment. A wide variety of type openings are available to meet most marking requirements.

## MONODE STEEL STAMP WEDGE TYPE

Precision ground knurl type for standard 3 inch diameter holders.  
 X= character size

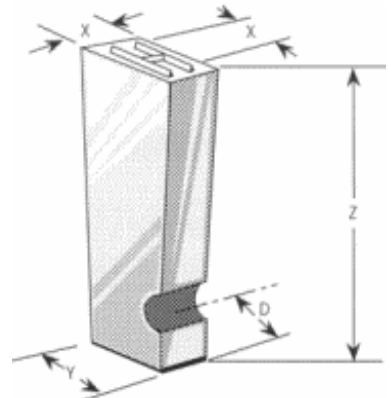

- STEEL TYPE
- ROLL DIES
- HAND STAMPS
- HOT STAMPS
- DIE INSERTS
- CUSTOM ENGRAVING
- E.D.M. SERVICES
- MARKING MACHINERY

## MONODE™ STEEL STAMP, INC.

149 High Street • New London, Ohio 44851  
Phone: 419-929-3501 • Fax: 419-929-8806

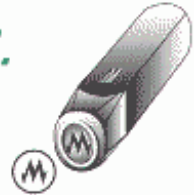

### Parts Marking Problem Solver SAVE HASSLES - SAVE MONEY



- ELECTRO-CHEMICAL ETCHING
- PAD PRINTING SYSTEMS
- PMS 2001 . . .  
COMPUTERIZED PIN MARKING SYSTEM
- SILICONE DIES, HOT STAMPING
- INDUSTRIAL RUBBER STAMPS



**MONODE™**  
STEEL STAMP, INC.

**Imperial™**  
STAMP & ENGRAVING

- HEAVY DUTY HAND STAMPS
- CUSTOM ENGRAVED MARKING DIES
- MARKING MACHINES, TOOLING & FIXTURES
- SERIALIZING HEADS, TYPE HOLDERS  
AND ROLL STAMPS

### The MONODE Family of Marking Products

## CUSTOM ENGRAVED MARKING DIES

Manufactured of high quality tool steels  
to meet your stamping or roll marking needs.

*Competitive pricing, on time deliveries.  
Our commitment to you . . .  
Service, Innovation, Quality . . .  
Reflected by a good impression.*

MONODE™ STEEL STAMP, INC.

